

## 350W Single Output Switching Power Supply 350W 单路输出开关电源

HF350W-SE Series  
HF350W-SE 系列



### FEATURES 产品特性

- Economical design, competitive price 经济型设计, 高性价比
- Compact size, high reliability 小体积, 高可靠性
- Built-in fan speed control 内置风扇速度控制
- Approvals: CE (LVD) 认证
- Protections: overload/ over voltage/ over temp./ short circuit 带过载、过压、过温、短路保护
- 2 years warranty 两年质保
- F635A 215 x 115 x 50mm 外形尺寸

### SPECIFICATIONS 规格书

Input Voltage 输入电压	170~264VAC (210~370VDC)
Input Current 输入电流	< 4.5A
Input Frequency 输入频率	47~63Hz
Inrush Current 启动冲击电流	cold start, 60A/230V 冷启动, 60A/230V
Input Leakage Current 输入漏电流	< 0.7mA/230VAC
Line Regulation (full load) 电网调整率 (满载时)	± 0.5%
Voltage Adjust Range 输出电压调节范围	± 10%
Output Overload Protection 输出过载保护	105~130%, shut off, re-power on to recover 105~130%, 关断, 重启恢复
Output Over Voltage Protection 输出过压保护	115~150%, shut off, re-power on to recover 115~150%, 关断, 重启恢复
Short Circuit Protection 短路保护	shut off, re-power on to recover 关断, 重启恢复
Rise Time 上升时间	50ms
Hold up Time 保持时间	20ms
Mechanical Feature 机械特性	metal enclosed 金属外壳
Dimensions 外形尺寸	215 x 115 x 50mm (L x W x H) 215 x 115 x 50mm (长x宽x高)

Operating Temperature 工作温度	-20°C ~+70°C(ref. derating curve) -20°C ~+70°C(参见减额曲线)
Storage Temperature 储存温度	-20°C ~+85°C
Operating Humidity 工作湿度	20%~93%RH(non condensing) 20%~93%RH(无凝露)
Storage Humidity 储存湿度	20%~95%RH(non condensing) 20%~95%RH(无凝露)
MTBF 平均无故障工作时间	>100,000 hours >100,000 小时
Cooling 冷却方式	fan 风冷
Safety Standards 安全标准	design meet GB4943, UL60950, EN60950 设计符合 GB4943, UL60950, EN60950
Withstand Voltage 绝缘强度	I/P -O/P: 3.0KVAC/1min I/P - PE: 1.5KVAC/1min O/P-PE: 0.5KVAC/1min
Vibration 振动	10~150Hz, 2G 10min/1cycle, 30min each along X, Y, Z axes 10~150Hz, 2G 10分钟/周期, 30分钟/X, Y, Z轴每个方向
Connection 接线端子	9P/9.5mm screw terminal block 螺丝接线式接线端子
Screw/Torque 螺丝/扭力	M4/ 1.2N.m
Wire 接线范围	22-12AWG 4.0mm <sup>2</sup>
Packing 包装	0.89kgs 每台, 16pcs/16.2kgs/ 0.035CBM per carton 每箱

Model No. 型号	DC Output 直流输出	Rated Power 额定功率	Load Regulation 负载调整率	Voltage Tolerance 电压精度	Ripple & Noise (max.) 纹波和噪声	Efficiency 效率
HF350W-SE-5	5V 60.0A	300.0W	2.0%	± 1%	120mVp-p	78%
HF350W-SE-12	12V 29.0A	348.0W	0.5%	± 1%	150mVp-p	80%
HF350W-SE-15	15V 23.0A	345.0W	0.5%	± 1%	150mVp-p	81%
HF350W-SE-24	24V 14.6A	350.4W	0.5%	± 1%	150mVp-p	84%
HF350W-SE-36	36V 9.7A	349.2W	0.5%	± 1%	200mVp-p	86%
HF350W-SE-48	48V 7.3A	350.4W	0.5%	± 1%	240mVp-p	86%

\* 5~48VDC output all available 其它规格均可定制

### NOTE 备注

1. All parameters are measured at 230VAC input, rated load and 25°C ambient temperature.  
上述所有参数的测试条件为 230VAC 输入电压, 额定负载和 25°C 室温。
2. Line regulation is measured from low line to high line at rated load.  
电网调整率是在额定负载条件下从低电网到高电网的输出电压变化率。
3. Load regulation is measured from 0% to 100% of rated load for single output models. For multi-output models, it is measured from 20% to 100% of rated load, and other output at 60% rated load.  
负载调整率是负载电流从额定负载的 0% 到 100% 变化时的输出电压变化率。
4. Ripple & noise are measured at 20MHz of bandwidth by using a 12" twisted pair-wire terminated with a 0.1uF & 47uF parallel capacitor.  
纹波和噪声是用 20MHz 带宽的示波器, 通过一根 12" 长的末端并接 0.1uF 和 47uF 电容的双绞线进行测量的。
5. The power supply is regarded as a component which will be installed into the final equipment. The final equipment must be re-confirmed that it still meets EMC directives.  
开关电源被视为整机的一个部件。整机是否符合 EMC 指令还需重新测试并验证。

Derating Curve 减额曲线

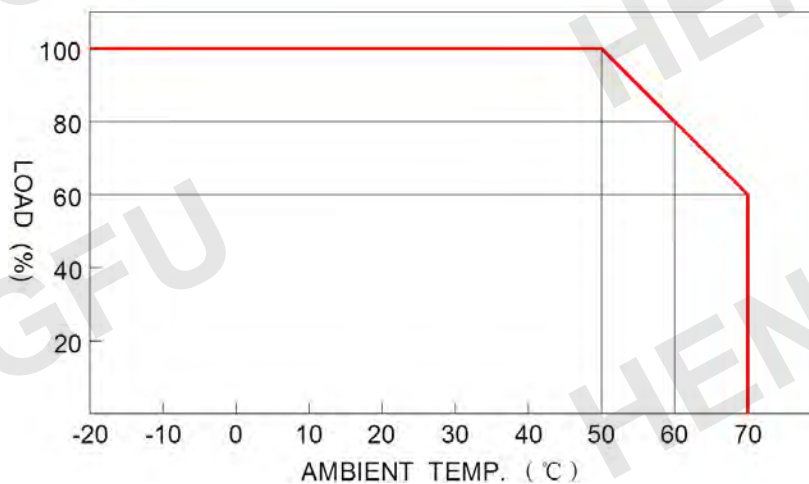

Drawing 安装图纸

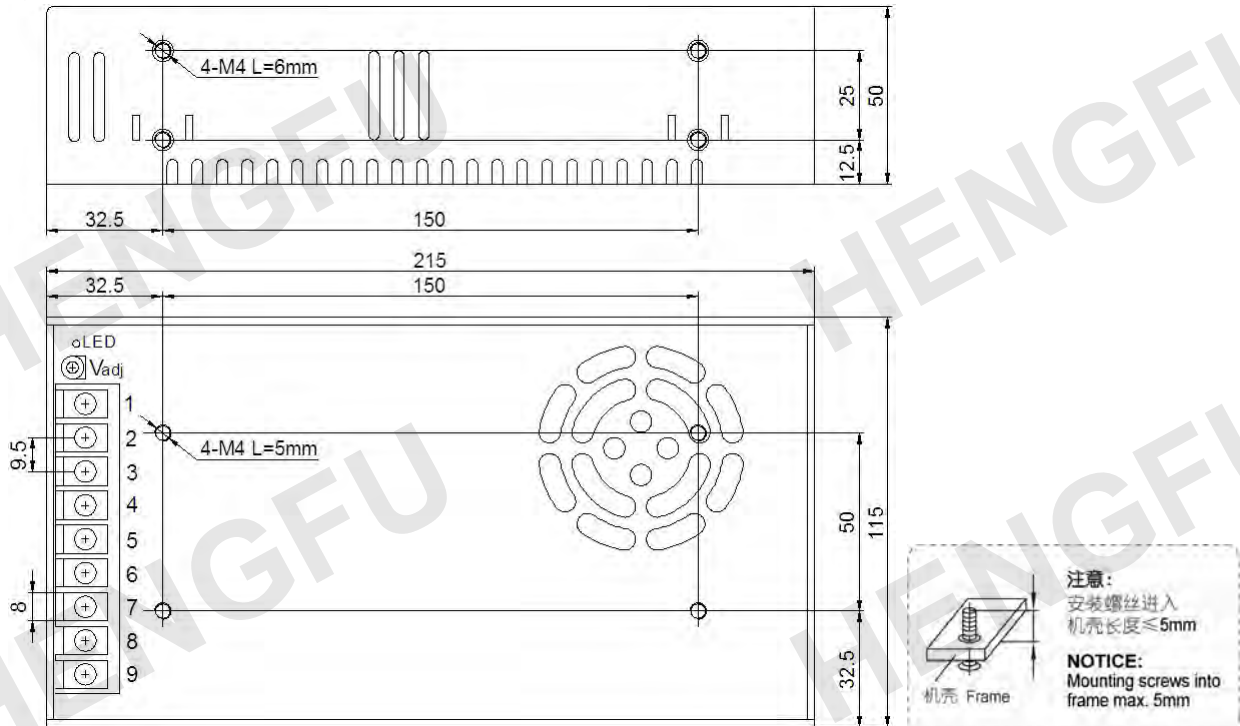

Terminal Pin No. Assignment 接线端子排布:

Pin No. 位号	Assignment 排布	Pin No. 位号	Assignment 排布
1,2,3	DC OUTPUT +V	7	PE
4,5,6	DC OUTPUT -V	8	AC/N
		9	AC/L